

**TOWN OF CLIFTON
ARCHITECTURAL REVIEW BOARD
REGULAR MEETING
THURSDAY, JUNE 24, 2021, 7:30 PM
ELECTRONIC MEETING, VIA ZOOM**

Until further notice from the Mayor of Clifton, and in accordance with the Resolution of the Architectural Review Board Commission regarding Remote Participation by Electronic Means Policy and the Town Council Continuity of Government Methods, to the Architectural Review Board and Authorizing Remote Participation by Electronic Means Without a Physical Quorum Being Present Pursuant to Virginia Law, the Town of Clifton Architectural Review Board is holding all Meetings noticed herein electronically for the purpose of continuity of government of the Town of Clifton.

The meetings will be conducted using Zoom teleconferencing audio and video service, and connection information will be provided to members of the public to afford the opportunity to citizens to witness the operation of the Town of Clifton government. Connection information is available from, and will be provided by, the Town Clerk or Chair of the Architectural Review Board upon receiving an emailed request directed to clerk@cliftonva.gov or royce.jarr@yahoo.com.

Present: Royce Jarrendt, Chair; Phyllis Lovett; Jeff Stein; Geri Yantis.
Staff: Amanda Christman, Town Clerk.
Absent: Council Representative Member Regan McDonald; Phoebe Peterson.

The Regular Meeting was called to order by Chair Jarrendt at 7:31 PM.

Order of Business:

1. Donald Gibson, The Hair Garage/12644 Chapel Road: Business Signage.
See attached application.

It was noted that the sign size is appropriate, and that it is to be mounted by a metal bracket on the side-elevation of the building, and the "Open" arrow sign is to be permanently removed. The phone number for the business is not approved to be on the sign.

- **Member Yantis moved to approve the sign with the stipulation that the phone number be omitted, seconded by Member Stein. The motion was approved by poll, 4-0.**

2. Royce Jarrendt for Dianne Charneco/12851 Redbird Ridge Road: Addition & Modifications to the existing structure.

See attached application.

The proposed addition and modification to the existing structure is to be constructed with asphalt shingles to match the existing, composite fascia & cornice trim to match existing, composite T&G vertical siding, stucco to match existing, wood doors, metal garage door to match existing, composite railing, and composite Windsor window product to be painted to match existing.

- **Member Stein moved to approve the application as submitted, seconded by Member Lovett. The motion was approved by poll, 3-0-1 (Chair Jarrendt abstained).**

3. David Guglielmi, Infill By Design/7184 Clifton Road: Guardrail.

See attached design sheet.

It was noted that a height of 36” would look better for a pedestrian guardrail, be less visible from the street and conforms with residential building code, unless the owners prefer the 42” height as shown on the design sheet. The owners indicated that they prefer the 36” height. Mr. Guglielmi noted that he is not sure how long the rail will be, since that requirement will be made by Fairfax County. Chair Jarrendt noted that location and structural stability is outside of the ARB’s purview.

- **Member Stein moved to approve a 36” tall pedestrian guardrail consisting of black metal, seconded by Member Yantis. The motion was approved by poll, 4-0.**

4. Business Sign Audit Project.

The Board discussed the specifics of the planned email that will be sent out to all business owners notifying them that the Governor’s state of emergency declaration expires on June 30, 2021, and that all temporary signage posted during the COVID-19 must now be removed or approved by the ARB.

In addition, a line will be added to the COA application to allow for HOA approvals where applicable.

5. Approve Draft April 2021 Meeting Minutes.

- **Member Yantis moved to approve the April 2021 Minutes with one revision for clarity, seconded by Member Lovett. The motion was approved by poll, 4-0.**

6. Adjournment.

The meeting was adjourned by general acclamation at 9:22 PM.

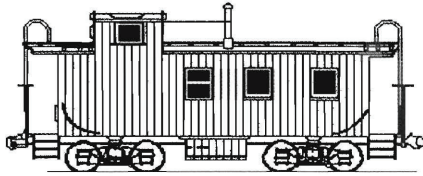

CLIFTON ARCHITECTURAL REVIEW BOARD
TOWN OF CLIFTON, VIRGINIA
APPLICATION FOR CERTIFICATE OF
APPROPRIATENESS

DATE OF APPLICATION: MARCH 27, 2021
NAME OF APPLICANT OR AGENT: The HAIR GARAGE, LLC
ADDRESS: 12644 CHAPEL ROAD #114
TELEPHONE: 703 863 9088 Email d.gibson@cliftonagency.com
LOCATION OF PROPERTY INCLUDING STREET ADDRESS AND TAX MAP
NUMBER: 12644 CHAPEL ROAD CLIFTON, VA 20124
GENERAL DESCRIPTION OF PROPOSAL:
SIGN FOR HAIR GARAGE

ATTACHMENTS:

- APPLICATION FEE*
- Two (2) HARD COPIES AND ONE ELECTRONIC COPY OF APPLICATION WITH PLATS, ARCHITECTURAL DRAWINGS, FLOOR PLANS, ETC.

I UNDERSTAND THAT ALL SUBMISSION REQUIREMENTS MUST BE MET BEFORE THE ARB WILL REVIEW AN APPLICATION

[Signature] 3/27/21
SIGNATURE OF APPLICANT OR AGENT DATE
CERTIFICATE ISSUED: x YES NO
(When DocuSigned by: Royce Jarrendt signed, this document becomes the "certificate of Appropriateness")
BY: Royce Jarrendt 5CFBE67F719240C... DS DS DS 7/21/2021
ARB MEMBERS' INITIALS JS GU PL DATE

CONDITIONS: The phone number must be omitted from the sign and the "Open" arrow sign is to be removed. The approved sign will be bracket-mounted on the side-elevation.

IF CERTIFICATE IS NOT TO BE ISSUED, THE ARB SHALL STATE THE BOARD'S REASON: _____

*Application fee:
Sign/Fence: \$10.00; if after installation: \$50.00
Addition/remodeling project up to 200 SF: \$100.00
Addition/remodeling project exceeding 200 SF \$250.00
New home construction: \$250.00

The applicant shall also pay any actual costs of any review fees incurred by the ARB, including any consultant's fees and other costs set forth in Virginia State Code Section 15.2-2286.

18"

**Size 18wx27h"
PVC non metallic
Matte Finish print.**

**THE HAIR
GARAGE**

*May all your hair days,
be good ones!*

27"

703-863-6588

thehairgarage.org

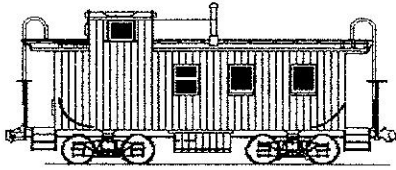

CLIFTON ARCHITECTURAL REVIEW BOARD
TOWN OF CLIFTON, VIRGINIA
APPLICATION FOR CERTIFICATE OF
APPROPRIATENESS

DATE OF APPLICATION: 4/15/2021
 NAME OF APPLICANT OR AGENT: Royce Jarrendt / for Dianne Charneco
 ADDRESS: 12639 Chapel Rd.
 TELEPHONE: 703 932-5762 Email Royce.jarr@yahoo.com
 LOCATION OF PROPERTY INCLUDING STREET ADDRESS AND TAX MAP
 NUMBER: 12851 Redbird Ridge Rd.
 GENERAL DESCRIPTION OF PROPOSAL:
Addition & modifications to the existing structure

ATTACHMENTS:

- APPLICATION FEE*
- Two (2) HARD COPIES AND ONE ELECTRONIC COPY OF APPLICATION WITH PLATS, ARCHITECTURAL DRAWINGS, FLOOR PLANS, ETC.

I UNDERSTAND THAT ALL SUBMISSION REQUIREMENTS MUST BE MET BEFORE THE ARB WILL REVIEW AN APPLICATION

Royce Jarrendt 6.11.2021
 SIGNATURE OF APPLICANT OR AGENT DATE
 CERTIFICATE ISSUED: X YES NO
 (When marked "YES" and signed, this document becomes the "certificate of Appropriateness")
 BY: Abstained 6/24/2021
 CHAIRMAN, ARB DATE
 ARB MEMBERS' INITIALS: RL MGY JS

CONDITIONS: To be constructed with asphalt shingles to match the existing, composite fascia & cornice trim to match existing, composite T&G vertical siding, stucco to match existing, wood doors, metal garage door to match existing, composite railing, and composite Windsor window product to be painted to match existing.

IF CERTIFICATE IS NOT TO BE ISSUED, THE ARB SHALL STATE THE BOARD'S REASON:

*Application fee:
 Sign/Fence: \$10.00; if after installation: \$50.00
 Addition/remodeling project up to 200 SF: \$100.00
 Addition/remodeling project exceeding 200 SF \$250.00
 New home construction: \$250.00

The applicant shall reimburse any indirect costs of any review fees imposed by the ARB, including any consultant's fees and other costs set forth in Virginia State Code Section 15.2-2002.

Retaining wall design attached

dguglielmi@yahoo.com <dguglielmi@yahoo.com>
Reply-To: "dguglielmi@yahoo.com" <dguglielmi@yahoo.com>
To: Clifton Clerk <clerk@cliftonva.gov>

Thu, Jun 10, 2021 at 5:09 PM

Please find attached the wall design, including metal guard rails to be used as an exhibit before the Town ARB. Thank you.

David L. Guglielmi
Managing Partner

Infill by Design, LLC
Tel: 703.623.4343

infillbydesign.com

Please find the attached drawing and calculations for the pedestrian guard rail.

Sincerely,

Jeremy Lucas, PE, SE

Senior Engineer

<image001.jpg>

904 Lakeside Drive, Lynchburg, VA 24501

434.846.1350

 **S001_SiteWalls REV 2.pdf**
1880K

REVISIONS:
 1 03/30/2021
 2 06/09/2021



MASTER
 ENGINEERS & DESIGNERS
 904 Lakeside Drive, Lynchburg, VA 24501
 434-846-1350 Fax: 434-846-1351

TIMBER RETAINING WALLS
 7184 CLIFTON ROAD
 CLIFTONG, VA

RETAINING WALL DETAILS

DATE ISSUED: 02/18/21
 SCALE: AS NOTED
 JOB. NO. 482-2240
 DESIGNED: JLL
 DRAWN: JLL
 CHECKED: JLL
 APPROVED: JLL

DRAWING NO. S1
 SHEET OF
 REVISION 2

STRUCTURAL NOTES

1. GENERAL REQUIREMENTS
 - 1.1. THE STRUCTURE HAS BEEN DESIGNED TO RESIST DESIGN LOADS ONLY AS A COMPLETED STRUCTURE. APPLICATION OF CONSTRUCTION LOADS TO THE PARTIALLY COMPLETED STRUCTURE SHALL BE CONSIDERED BY THE CONTRACTOR AND INCLUDED IN THE DESIGN OF SHORING, BRACING, FORMWORK, AND OTHER SUPPORTING ELEMENTS PROVIDED FOR CONSTRUCTION OF THE STRUCTURE.
 - 1.2. CONTRACTOR SHALL CHECK AND VERIFY ALL DIMENSIONS, REPORTING ANY DISCREPANCIES TO THE ENGINEER BEFORE PROCEEDING WITH THE WORK.
2. APPLICABLE CODES AND STANDARDS
 - 2.1. "VIRGINIA RESIDENTIAL CONSTRUCTION CODE" (2015 INTERNATIONAL RESIDENTIAL CODE).
 - 2.2. ANS/AWC NDS-2012 "NATIONAL DESIGN SPECIFICATION FOR WOOD CONSTRUCTION."
3. DESIGN LOADS
 - 3.1. LIVE LOAD SURCHARGE - RESIDENTIAL YARD & DRIVEWAY 40 PSF
4. SOIL PARAMETERS
 - 4.1. BACKFILL IS NO 57 STONE WITH AN APPROXIMATE UNIT WEIGHT OF 110 PCF AND A PHI OF 30°. BACKFILL IS WRAPPED WITH FILTER FABRIC.
 - 4.2. IN SITU SOIL AT BOTTOM OF WALL IS ASSUMED TO HAVE AN ALLOWABLE BEARING PRESSURE OF 2,000 PSF AND A UNIT WEIGHT OF 110 PCF.
5. MATERIALS
 - 5.1. DIMENSIONED LUMBER #2 SPRUCE/PINE/FIR OR BETTER GRADE
 ALL LUMBER SHALL BE PRESERVATIVE TREATED FOR INGROUND USE (AWPA USE CATEGORY UC4B OR BETTER)

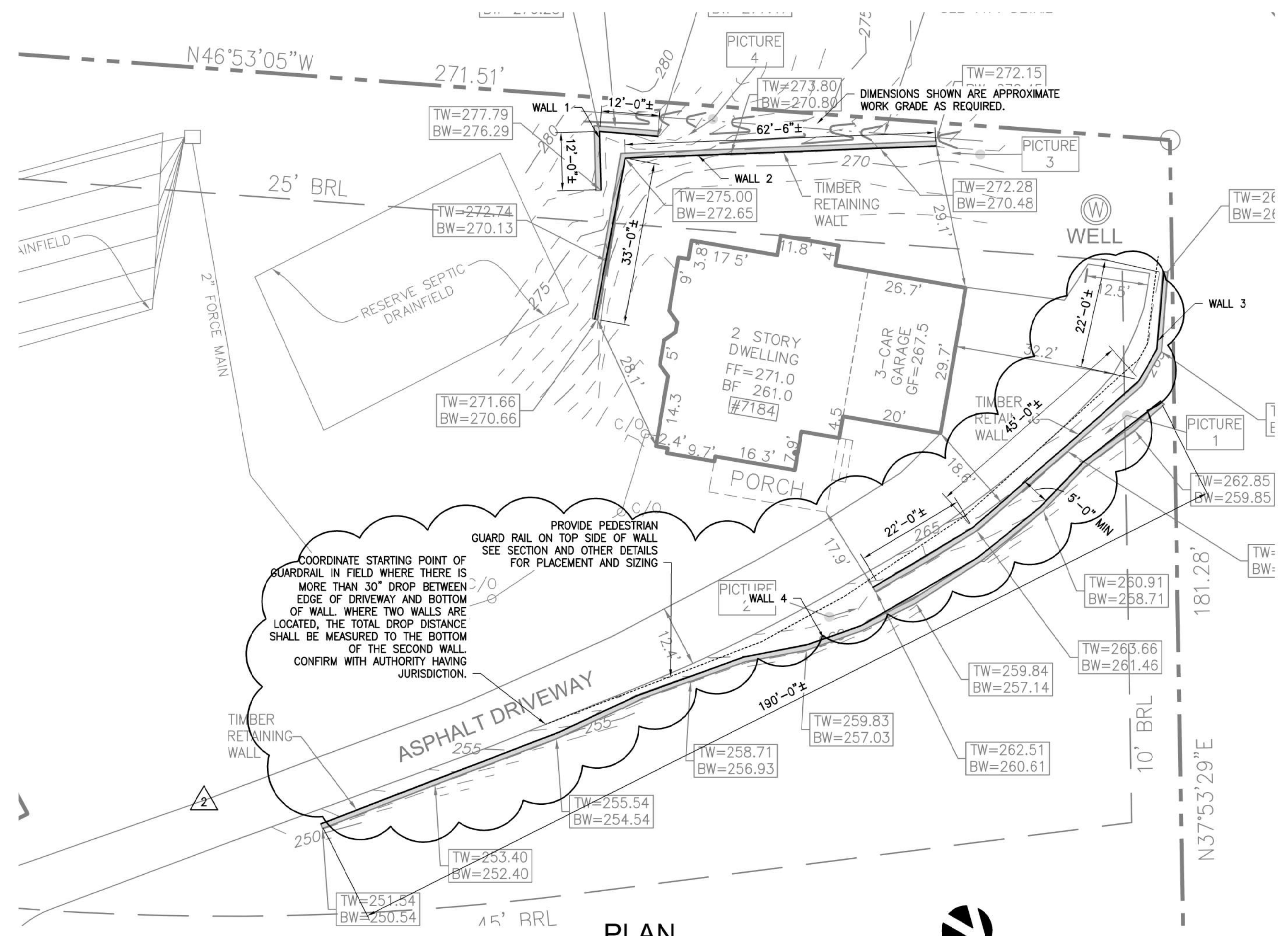

PLAN
 SCALE: 1/16"=1'-0"

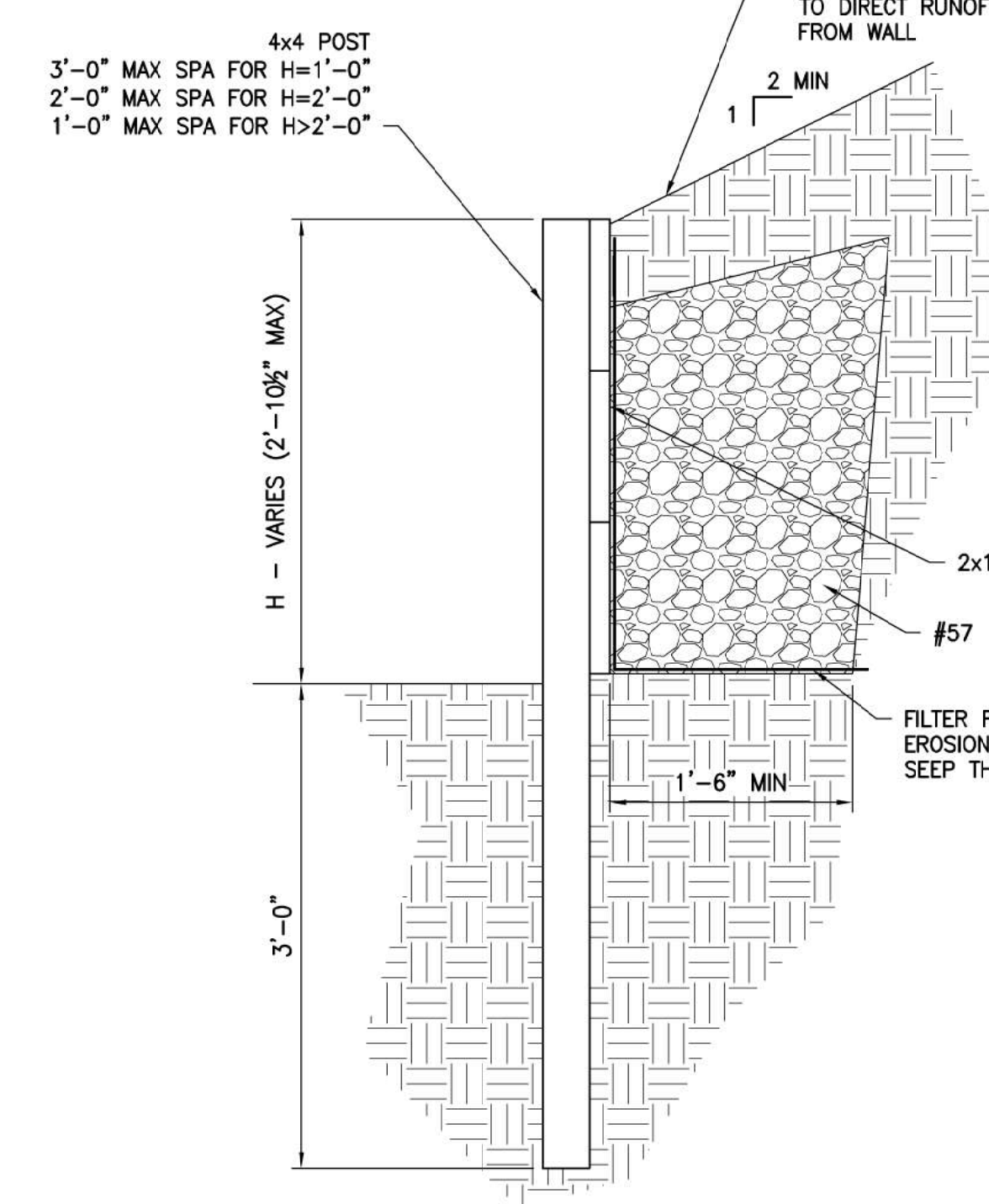

DETAIL - WALL 1 AND 2
 SCALE: 1"=1'-0"

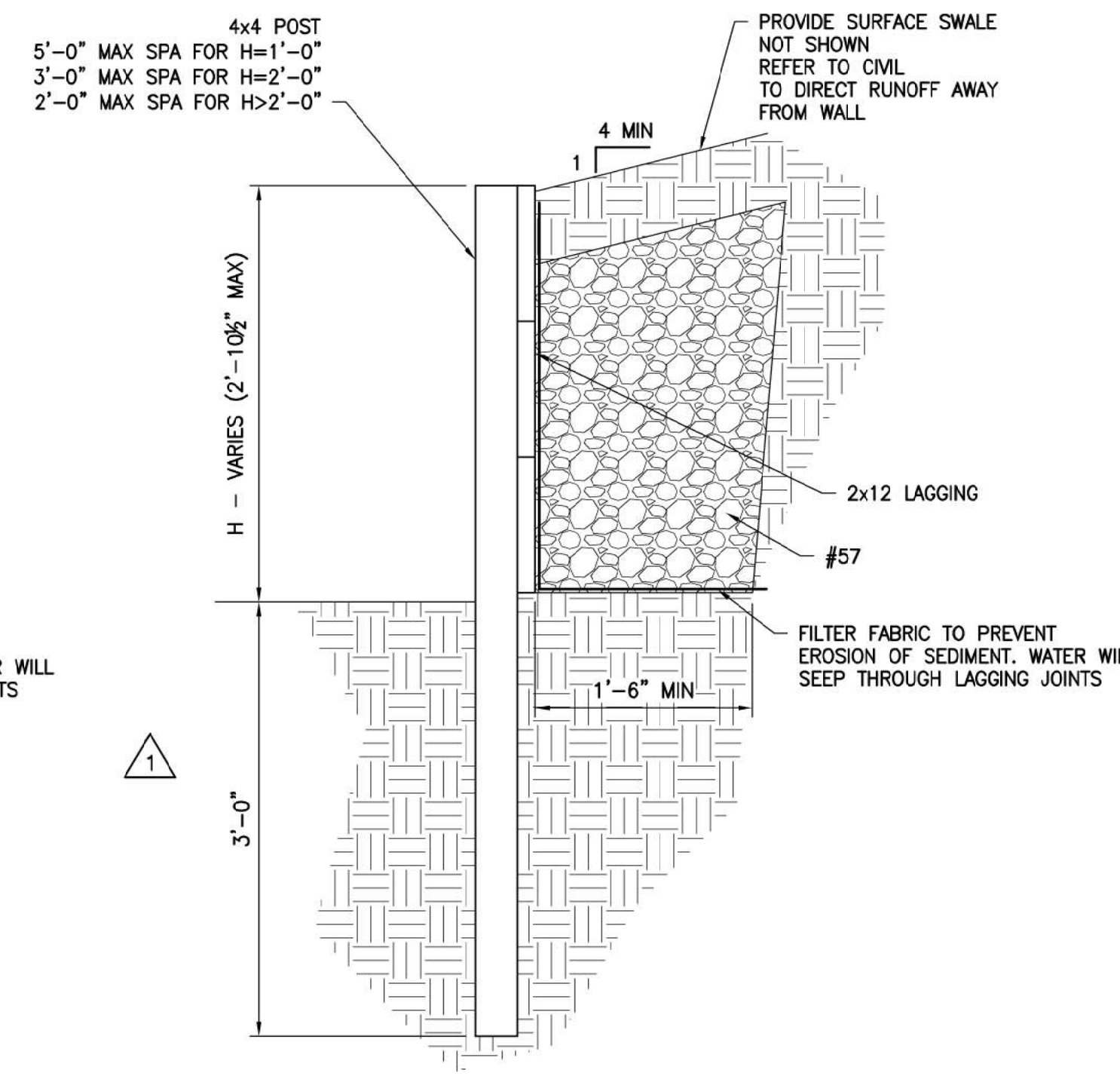

DETAIL - WALL 3 AND 4
 SCALE: 1"=1'-0"

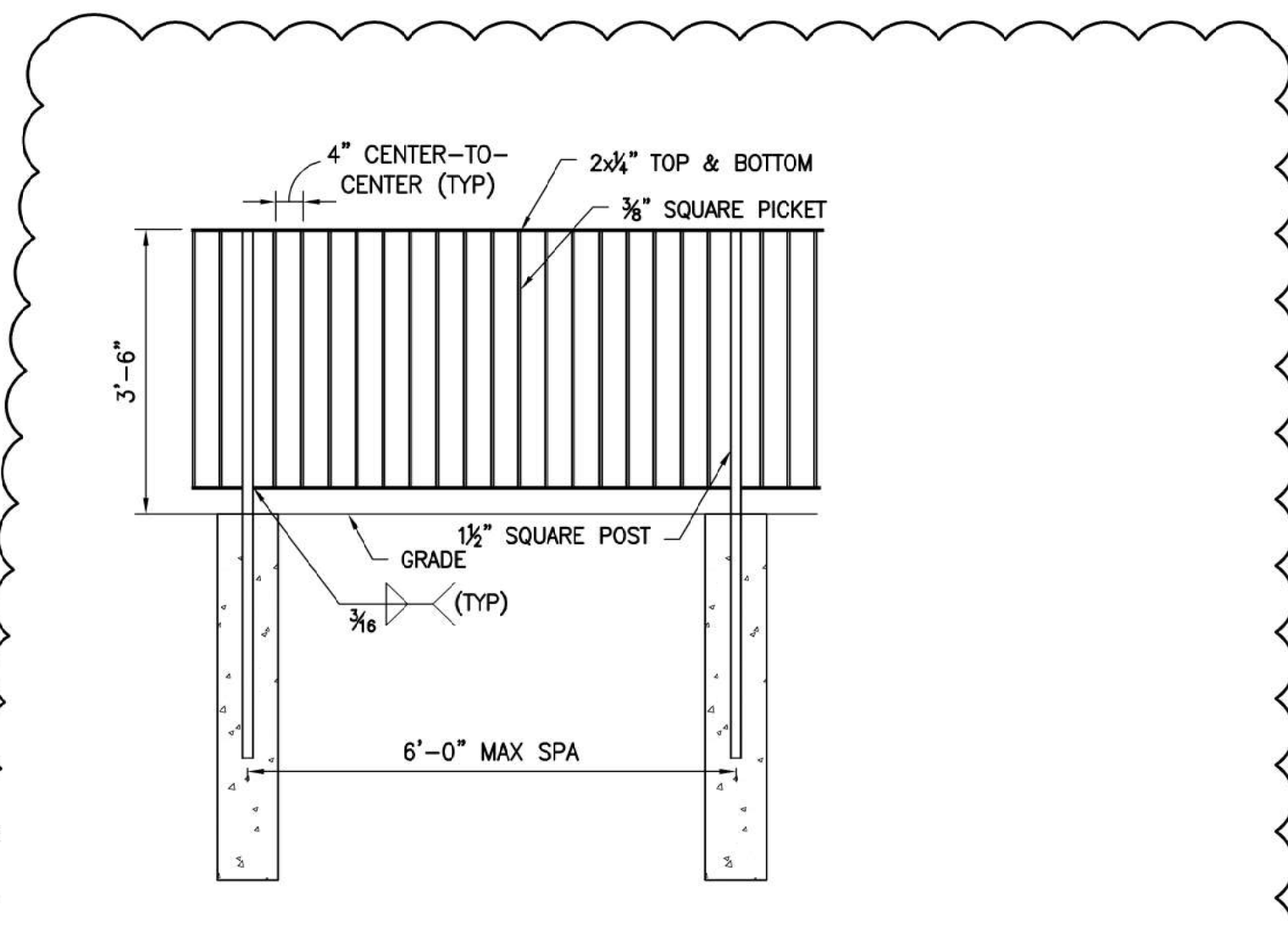

PEDESTRIAN GUARD ELEVATION
 SCALE: 1/2"=1'-0"

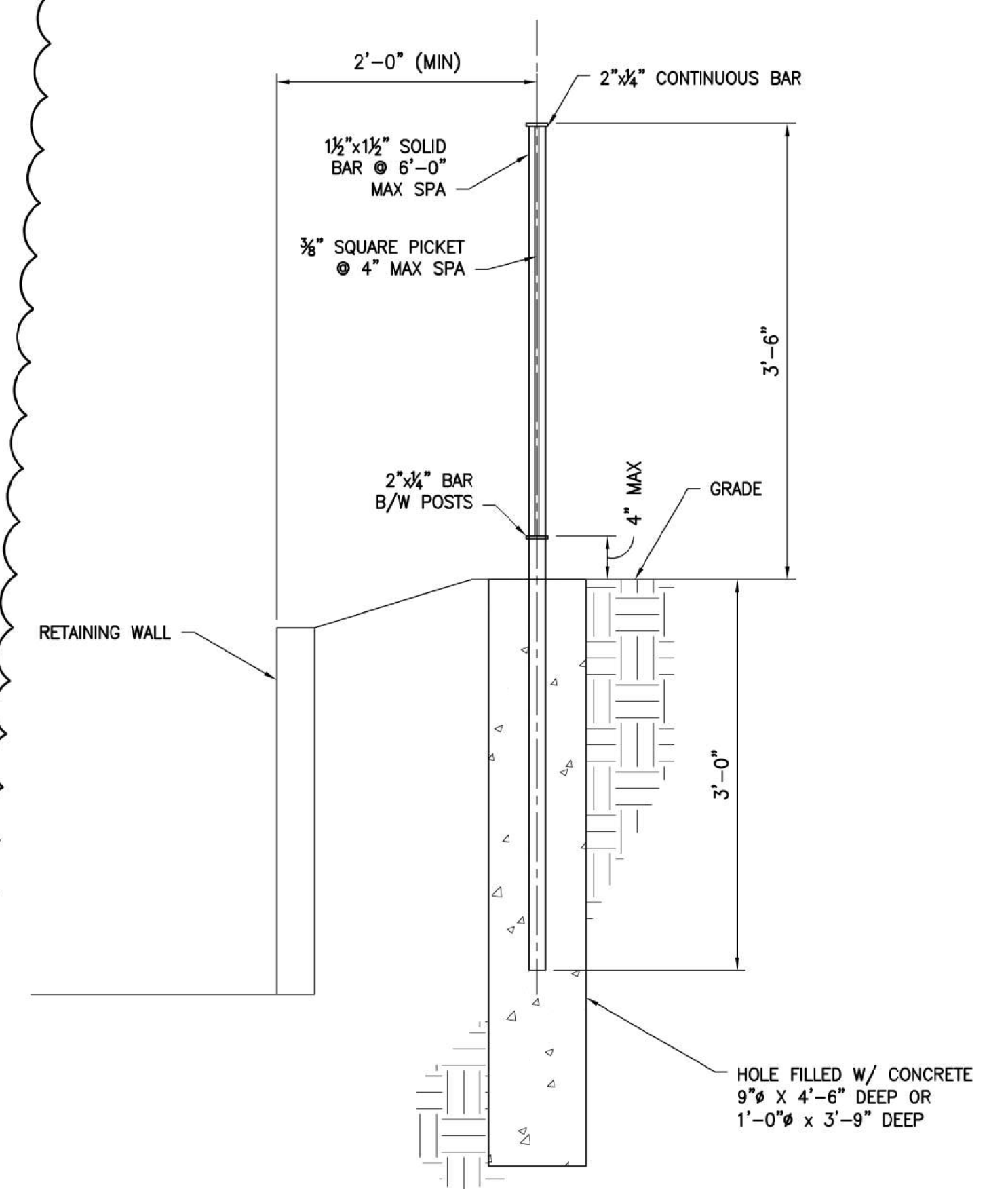

PEDESTRIAN GUARD RAIL - SECTION
 SCALE: 1"=1'-0"

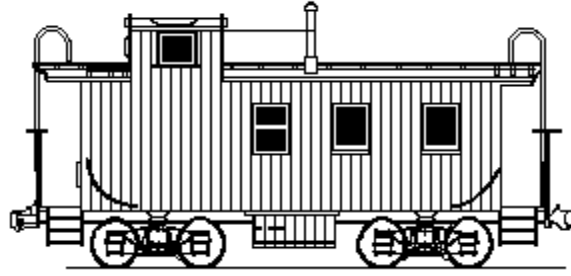

**TOWN OF CLIFTON
ARCHITECTURAL REVIEW BOARD
REGULAR MEETING
THURSDAY, JUNE 24, 2021 7:30 PM
ELECTRONIC MEETING, VIA ZOOM**

Until further notice from the Mayor of Clifton, and in accordance with the Resolution of the Architectural Review Board Commission regarding Remote Participation by Electronic Means Policy and the Town Council Continuity of Government Methods, to the Architectural Review Board and Authorizing Remote Participation by Electronic Means Without a Physical Quorum Being Present Pursuant to Virginia Law, the Town of Clifton Architectural Review Board is holding all Meetings noticed herein electronically for the purpose of continuity of government of the Town of Clifton.

The meetings will be conducted using Zoom teleconferencing audio and video service, and connection information will be provided to members of the public to afford the opportunity to citizens to witness the operation of the Town of Clifton government. Connection information is available from, and will be provided by, the Town Clerk or Chair of the Architectural Review Board upon receiving an emailed request directed to clerk@cliftonva.gov or royce.jarr@yahoo.com.

Order of Business:

1. Donald Gibson, The Hair Garage/12644 Chapel Road: Business Signage.
2. Royce Jarrendt for Dianne Charneco/12851 Redbird Ridge Road: Addition & Modifications to the existing structure.
3. David Guglielmi, Infill By Design/7184 Clifton Road: Guardrail.
4. Business Sign Audit Project.
5. Approve Draft April 2021 Meeting Minutes.
6. Adjournment.