

Adopted by the Town Council on October 4, 2022 as revised.

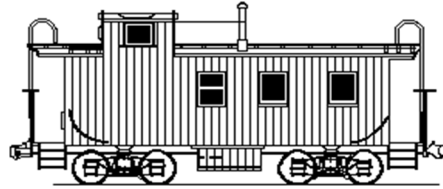

**CLIFTON TOWN COUNCIL MEETING
TUESDAY, SEPTEMBER 6, 2022, 7:30 PM
ELECTRONIC MEETING VIA ZOOM
12641 CHAPEL ROAD
CLIFTON, VA 20124**

In accordance with the Town of Clifton's Declaration of a Local Emergency due to the COVID-19 pandemic under Virginia Code § 44-146.21 which enables the Town of Clifton Government bodies to conduct Town business through electronic public meetings under Virginia Code § 2.2-3708.2, the Town of Clifton Town Council is holding the Meeting noticed herein electronically for the purpose of continuity of government of the Town of Clifton.

The meeting will be conducted using Zoom teleconferencing audio and video service, and connection information will be provided to members of the public to afford the opportunity to citizens to witness the operation of the Town of Clifton government. Connection information is available from, and will be provided by, the Town Clerk.

Present: Mayor Bill Hollaway; Vice Mayor Regan McDonald; Councilmember Steve Effros; Councilmember Patrick Pline; Councilmember Darrell Poe; Councilmember Lynn Screen.

Staff: Amanda Christman, Town Clerk; Nick Orrison, Town Treasurer.

The Regular Meeting was called to order by Mayor Hollaway at 7:31 PM.

Order of Business:

1. Report of the Town Clerk.

- **Mayor Hollaway moved to approve the August 2, 2022 Regular meeting Minutes as presented, seconded by Councilmember Effros. The motion was approved by poll, 6-0.**

2. Report of the Treasurer.

- **Mayor Hollaway moved to approve payment of the invoice from Maureen Gilmore in the amount of \$1,075 for legal services rendered, seconded by Councilmember Effros. The motion was approved by roll-call: Hollaway: aye; McDonald: aye; Effros: aye; Poe: Aye; Pline: aye; Screen: aye.**

3. Citizen's Remarks.

None.

4. Reports of Committees:

a. Planning Commission.

No report.

b. Report of the Zoning Administrator.

No report.

c. Architectural Review Board.

Vice Mayor McDonald reported that a Certificate of Appropriateness was issued for exterior signage for Signature Aesthetics located at 12642 Chapel Road.

d. Streetscape Committee.

No report.

5. Unfinished Business:

a. Addition of ADA Accessible Parking Spaces in Town Parking Lot - Report.

Vice Mayor McDonald reported that the price quote to modify several existing parking spaces to be ADA- accessible was less than the cost that was previously approved by the Council, and since then, the two ADA spaces have been created and are now being used by permitted motorists.

b. Acquisition of Speed Alert Signs for Town of Clifton – Review and Approve Proposal.
See attached proposal and communications.

Adam Trost, of Main Street: traffic on Main Street could be improved by full three-way stops at certain intersections. He requested the restoration of the speed hump in front of his house and the installation of signs to remind drivers of their speed. He noted that his residence is most affected by Clifton Road traffic heading south and suggested that signs may slow down some drivers, but that repercussions might be necessary to deter habitual speeders. He is in favor of speed humps and possibly rumble strips.

Mayor Hollaway interjected that the Council should consider passing a Resolution enumerating the specific traffic-calming measures that the Town wants, to be submitted to VDOT in conjunction with Supervisor Herrity and the Town's elected state representatives.

Jim Chesley, of Main Street: the speed alert signs can only be attached to poles that have power supply, such as the one by the McDonalds' house, and that NOVEC will install the approved signs at no cost to the Town, saving several thousand dollars. He added that Clifton Road approaching Newman Road was recently repaved, which caused the rumble strips to be removed and VDOT should be alerted. He also asked about involving the police department for speed enforcement assistance.

Councilmember Effros noted that police officers should be posted at both ends of Town for motorcycle events and on Saturdays and Sundays. He cautioned that VDOT regulations require 250 feet between each speed moderating device, which has impeded speed control measures in the past, and noted that speed humps must be low enough to accommodate emergency response vehicles.

- **Mayor Hollaway moved to approve the Town's acquisition of the four speed alert radar message signs as presented within proposal from All Traffic Solutions dated August 3, 2022 in the amount of \$14,642, seconded by Councilmember Poe. The**

Adopted by the Town Council on October 4, 2022 as revised.

motion was approved by roll-call: Hollaway: aye; McDonald: aye; Effros: aye; Poe: Aye; Pline: aye; Screen: aye.

Mayor Hollaway summarized the proposed Resolution of the Council, namely, that the Town wants: 1). the restoration of the speed hump on Main Street to be as high as possible within VDOT's standards (including to accommodate emergency response vehicles); 2). the reinstallation of the previously existing rumble strips on Clifton Road near Clifton Elementary School that were removed by the recent repaving effort; and 3). the addition of new rumble strips or a speed hump to be installed coming from south of Town on Clifton Road where so many accidents have occurred.

Councilmember Pline indicated that he is not in favor of rumble strips behind his house due to the noise that would be generated.

Vice Mayor McDonald noted that painting the curve of Clifton Road coming from south of Town may be a quieter option that may help prevent some accidents, and Councilmember Effros added that perhaps reflective road studs could be embedded in that area to assist drivers in seeing the curve when dark.

Susan Wright, of Clifton Road: would like a speed hump installed on Clifton Road on the south end. She noted that the speed limit is 25 mph in that area and indicated that a speed hump would be preferable to rumble strips. She reported that four accidents have occurred in her driveway in the last five years.

Councilmember Screen suggested that the use of solar powered signs could be explored for areas of need where there currently is no power supply. Mr. Chesley offered that solar power is an optional add-on for the signs that have been approved for purchase.

- **Councilmember Effros moved to request the restoration of the speed hump on Main Street to be as high as possible within VDOT's standards (including to accommodate emergency response vehicles); the reinstallation of the previously existing rumble strips on Clifton Road near Clifton Elementary School that were removed by the recent repaving effort; and the addition of new rumble strips or a speed hump to be installed coming from south of Town on Clifton Road where so many accidents have occurred, seconded by Mayor Hollaway. The motion was approved by poll, 5-1 (Mayor Hollaway, Vice Mayor McDonald, and Councilmembers Effros, Poe and Screen – Aye; Councilmember Pline -Nay).**

c. Holiday Lighting for Town of Clifton - Update.

Mayor Hollaway reported that none of the unsolicited proposals provided by Precision Holiday Lighting made economic sense for a Town of Clifton's size because of their price, and that other options for the tree lighting should be pursued, as has been done in prior years. Councilmember Poe volunteered to obtain the previous year's information from the Parks Committee Chair.

6. New Business:

a. Fairfax County Police Department – Sully Commander Community Meeting – Planning for November 17.

Adopted by the Town Council on October 4, 2022 as revised.

Mayor Hollaway updated the Council on the two new FCPD commanders who are planning to come meet with the Clifton Community at the Town Hall on November 17. Information will be circulated to the public prior to the event.

b. Clifton Day – October 9:

i. Request to Use Town Properties and Place Banner over Main Street.

- **Mayor Hollaway moved to approve the request for the Clifton Betterment Association to use Town property for Clifton Day, scheduled to take place on October 9, and to place a banner over Main Street starting September 24 and to be removed within one week after the event, seconded by Councilmember Effros. The motion was approved by poll, 6-0.**

c. Clifton Haunted Trail – October 29:

i. Presentation, Request for Advance Funding and Place Banner over Main Street.

- **Mayor Hollaway moved to authorize the placement of a banner over Main Street for the Clifton Haunted Trail on October 29, to go up following Clifton Day and to be removed within one week after the event, seconded by Councilmember Poe. The motion was approved by poll, 6-0.**
- **Mayor Hollaway moved to approve up to \$17,000 for the Haunted Trail in advance of the event, seconded by Councilmember Effros. The motion was approved by roll-call: Hollaway: aye; McDonald: aye; Effros: aye; Poe: Aye; Pline: aye; Screen: aye.**

d. Banner Request for Clifton Lions Club/DEA Drug Take Back Day – October 29 – Banner Up October 15, Down One Week After Event.

After it was noted that the Town’s banner hanging hardware can accommodate only one banner at a time, the banner request was withdrawn due to a conflict with the timing of the Haunted Trail banner. The Clerk was directed to publicize the event via a community-wide email announcement. It was recommended that the CBA be asked to help spread the word, as well.

e. Holiday Arts & Crafts Festival – Town of Clifton and Art Guild – December 3.

- **Mayor Hollaway moved to approve the Holiday Arts and Crafts Festival, to be co-hosted by the Town of Clifton and the Art Guild on December 3 at the Town Hall, amended by Councilmember Effros to invite the Town’s local businesses to participate, seconded by Councilmember Effros. The motion was approved by poll, 6-0.**

f. Holiday Tree Lighting Event – December 3.

Councilmember Poe will look into arranging the contract, with additional information to be provided at an upcoming Council meeting.

g. Holiday Homes Tour.

Councilmember Screen reported that one local home has committed so far, and four more locations are needed. As in the past, shuttles could be provided for locations near enough to the Town.

h. Second Baptist Church Update – New Pastor – Rev. Dr. Jerome Allen Bell.

Adopted by the Town Council on October 4, 2022 as revised.

Mayor Hollaway reported on the installation of the Reverend Dr. Bell as the new pastor for the Second Baptist Church of Clifton and invited interested people to attend the new weekly in-person services on Sundays at 11 AM starting in October.

i. Project Commitment Tracking Process.

The Council noted that projects can be discussed on a going-forward basis on an as-needed basis as inquiries are received.

7. Adjournment.

- **Councilmember Poe moved to adjourn, seconded by Councilmember Effros. The motion was approved by poll, 6-0.**

The meeting was adjourned at 9:13 PM.



All Traffic Solutions Inc.
 14201 Sullyfield Circle,
 Ste 300
 Chantilly, VA 20151
 Phone: 814-237-9005
 Fax: 814-237-9006
 DUNS #: 001225114
 Tax ID: 25-1887906
 CAGE Code: 34FQ5

QUOTE Q-69881

DATE: 08/03/2022

PAGE NO: 1

Mail Purchase Orders to:

3100 Research Dr.
 State College, PA
 16801

Contract:

Questions contact: MANUFACTURER: All Traffic Solutions

Max Wicklein
 (571) 321-5452
 x
 mwicklein@alltrafficsolutions.com

Independent Sales Rep:

BILL TO:

Town of Clifton-VA
 VA

Billing Contact:

SHIP TO:

Town of Clifton-VA
 VA
 Attn: Jim Chesley

PAYMENT TERMS:
 Net 30

CUSTOMER: Town of Clifton-VA

CONTACT:(703) 362-2129

ITEM NO:	DESCRIPTION:	QTY:	EACH:	EXT. PRICE:
4000885	SpeedAlert 18B Radar Message Sign (RMS); base unit w/ mounting bracket, Can be Upgraded to TraffiCloud	4	\$3,338.00	\$13,352.00
4000958	AC supply, 3.0A, 12VDC out, 120/240VAC 50/60 Hz in, inside battery cover (Sh12,Sh15,SA18,iA18)	4	\$250.00	\$1,000.00
4000793	Violator Strobe, Dual; Hardware for SpeedAlert 18, flash helps draw attention to the driver's speed. Requires color assignment PN.	4	\$400.00	\$1,600.00
4000826	Strobe Color: Red and Blue (Requires 4000793 Dual Violator Strobe)	4	\$0.00	\$0.00
4000641	Shipping and Handling Common Carrier	1	\$190.00	\$190.00
4001190	Discount - New Purchase	1	(\$1,500.00)	(\$1,500.00)

Special Notes:

SALES AMOUNT: \$14,642.00

TOTAL USD: \$14,642.00

Duration: This quote is good for 60 days from date of issue.

Shipping Notes: All shipments shall be FOB shipper. Shipping charges shall be additional unless listed on quote.

Taxes: Taxes are not included in quote. Please provide a tax-exempt certificate or sales tax will be applied.

Warranty: Unless otherwise indicated, all products have a one year warranty from date of sale. Warranty extensions are a component of some applications that are available at time of purchase. A Finance Charge of 1.5% per month will be applied to overdue balances. GSA GS-07F-6092R

Authorization: By Signing below, I indicate that my organization does not require a purchase order and I am authorized to commit my organization to this order.

Signature: _____ Date: _____

Print Name: _____ Title: _____



PRODUCT SPECIFICATIONS:

SPEEDALERT 18 RADAR MESSAGING SIGN – B UNIT

SpeedAlert Radar Message Sign

- **SpeedAlert 18 (SA18):** 18" x 28" full matrix
(SpeedAlert 24 (SA24) 24" x 60" full matrix also available – see separate SpeedAlert 24 Spec Sheet)
- Size and weight without battery
 - o 30"x20" x 2.74" (without YOUR SPEED sign), 29 lbs
- Full matrix display
- **Universal mounting system:** Attach to pole, trailer or vehicle hitch mount
- Radar: Adjustable sensitivity, K Band (24.15 GHz), FCC Certified, no license required, +-1 mph accuracy, 12 degree square pickup area, range: 1500+ ft., 5-105 mph (8-150 kph)
- Meets MUTCD Specifications

SpeedAlert Operation Modes

- **Message Mode:** Display one message, up to six screens
- **All Messages:** Sequence all messages in sign memory
- **Speed Display:** Display approaching vehicle's speed
- **Dependent Message:** Display targeted messages based upon vehicle's speed, up to six screens per message
- Changeable speed limit sign
- **Stealth or Display Off:** Collect traffic speed and volume data with no LED display, 'YOUR SPEED' sign easily removed
- **Schedule:** Change message and/or mode up to 13 times/day
- Collect vehicle volume by speed and time data in all modes
- Sign returns to last mode and configuration when power applied

SpeedAlert Programming Methods

On-Board Programming (standard on all units)

- Select operation mode
- Set Speed Limit
- Select message from sign's memory

ATS PC Sign Manager

Local Management using PC with USB connection standard with all signs, Bluetooth optional

- PC-based client software
- Connect to sign via USB or Bluetooth (optional)

ATS Android App: Local Management (Optional):

- Android OS wireless Bluetooth control local to unit
- Android device can be phone or WiFi device with Bluetooth

Local Management Features – PC and Android (Optional):

- Create and change messages, modes and settings
- Local data retrieval and management
- All traffic data and messages saved for online management and backup
 - o Retrieve data and save to TrafficCloud at no cost, generate limited reports online from hosted data. Extended reports available with TrafficCloud subscription
 - o Create message and save to TrafficCloud library, messages available on all ATS Android app or PC Sign Manager devices with TrafficCloud subscription

SpeedAlert Messages

- **SA18:** 1-2 line messages
 - o **1 line:** 10 1/4" H x 5.75" W characters, four per line
 - o **2 lines:** 7" H x 4" W characters, six per line
- Up to 6 screens per message
- Full graphics capability, each LED individually controllable
- Variable display time, flash and reverse rates for each screen
- Scroll through 25 user defined onboard messages using selector buttons built into sign, no training necessary
- Ability to sequence messages for up to 144 screen animation
- Message power efficiency calculator in software
- Actual sign preview and unlimited message storage using TrafficCloud Web-based Remote Management Service, ATS PC Sign Manager or ATS Android app
- Messages on sign retained when power removed
- Sign returns to last message when power applied
- Conditional Messaging – Accept local or remote data and dynamically display messages driven off data, and/or incorporate into messages

SpeedAlert Programming

Configure the following parameters via TrafficCloud Web-based Management System, ATS Android app or PC Sign Manager

- **Messages**
 - o Create and load message using 'Display Now' feature
 - o Load 24 messages into sign's memory
 - o Scroll messages in sign's memory
 - o Display signs stored in ATS Android app or PC Sign Manager
- **Speeds**
 - o Speed limit
 - o Maximum speed displayed
 - o Display on/off/specific mph activation
 - o Radar sensitivity (range)
 - o **Speed limit sign operation:** Change speed limit up to 13 times per day schedule
 - o Metric capable display with hundreds digit
 - o Set time via PC, Android or sync with cell signal (TrafficCloud)
 - o Sign firmware field and remotely upgradeable

Speed-Dependent Message System

- Different messages for each of five speed ranges
 - o No cars
 - o Cars <= speed limit
 - o Cars > Speed Limit, < x
 - o Cars > x < upper speed
 - o Cars > upper speed
- Ranges dependent on speed limit setting only, so simple speed limit change adjusts all dependent message ranges
- Independent maximum speed displayed setting
- Speed dependent messages can be any SA18 messages, including:
 - o 'YOUR SPEED' screen, 18" speed display digits
 - o 'SPEED LIMIT' screen, 18" speed limit display digits

Scheduling

- **All Days, Multiple Messages:** Schedule up to 50 different messages or modes for up to 13 different time periods in a 24 hour day, repeats in each 24 hour cycle
- **Seven Day, Multiple Messages:** Schedule different messages or modes for up to 13 different time periods in each 24 hour day for each of seven days, repeats in each seven day cycle; up to 50 different messages can be used over the 7-day period
- All messages and scheduling reside on the sign – no external hardware necessary
- Program schedule via ATS Android app or ATS PC Sign Manager, save to load onto multiple signs
- Internal real time clock, time and schedule maintained with power disconnected

SpeedAlert Data Logging Option

- **Local Data Collection:** ATS Android app or PC Sign Manager
 - o All data hosted in online database for anywhere access
 - o Download traffic data from sign with USB or Bluetooth connection
 - o 30 days of high volume data minimum storage on sign, Data collection rolls over when memory reaches capacity

- **Reports, Local Data Collection:**
 - o Summary page with average and 85th percentile speed, average daily volume, 10 mph pace speed, high and low speed, display mode
 - o Traffic counts by speed range, full day and time of day over selected date range with 5 mph resolution
 - o Vehicle counts by time range per day by hour
 - o Vehicle counts by speed range and time of day
- Reports, automatic data collection (TraffiCloud Web-based Management Services)
 - o Enhanced Summary with detail charts and graphs
 - o Compliance by speed range with 3 ranges
 - o Enforcement report showing highest speed and volume violators over selected locations
 - o Effectiveness report showing program performance

Construction

- ‘YOUR SPEED’ sign
 - o High intensity prismatic reflective background
 - o 24” x 8”
 - o 3.5” high MUTCD ‘C’ letters
- **LED Pixels:** Amber 595nm, 30 degree viewing angle, 100,000 hours, black background, (MUTCD compliant)
- **LED Density:** 0.6”x1” pitch, 18 x 48 pixel matrix
- **Radar:** K Band (24.15 GHz), FCC Certified, no license required, +-1 mph accuracy, 12 degree square pickup area, range: 1500+ ft., 5-105 mph (8-150 kph)
- Conformal coating on all circuit boards
- Integral handle
- Weatherproof, NEMA 4, IP65 sealed
- ¼” Tinted, non-glare, UV stabilized polycarbonate face
- Drip proof, vented battery compartments (2)
- Aluminium chassis, 14 ga, white powder coat finish, black powder coat front for maximum contrast for display visibility
- Tamper-resistant mounting hardware system, hardware, controls and battery access secured behind enclosure lock
- -40 to 160 F operating temperature range, 95% humidity non-condensing (-20F for Bluetooth communication, 5F for internal camera)

SpeedAlert Power

- **Power Input, Max:** 12 VDC, 3 A max, 36 W max
- Power saving circuitry and automatic dimming for ambient light conditions with adjustable dimming range and manual display brightness override
- **SpeedAlert 18 Power Options:**
 - o 16Ah LFP battery with built-in short circuit and reverse polarity protection circuitry; 1.5A 12.8 VDC output, 120VAC input automatic charger; Capacity for up to 2 batteries in unit for extended portable use
 - o Solar panel assist: 40W or 60W solar panel and bracket, Solar controller panel with 26Ah lead acid battery; 6A 120VAC automatic charger optional
 - o 100-220VAC AC power supply (6A 12VDC) in external NEMA 4 enclosure
 - o ATS 5 Trailer (batteries with optional solar assist: 235 or 470 Ah battery system, 40 or 60W solar option)
 - o ATS 3 Trailer, 100Ah battery and 40W solar option
- Battery level indicator on sign, ATS Android app, ATS PC Sign Manager or TraffiCloud Remote Management
- Auto recovery for battery with solar

Standard SpeedAlert System Components

- SpeedAlert Radar Message Display SA18
- Tamper resistant mounting plate and hardware
- Key
- On-board controls
- ATS PC Sign Manager software with USB cable

Optional SpeedAlert Components and Features

- ATS Android app, Bluetooth connectivity
- Padded carrying case
- Extra mounting brackets
- Speed activated relay closure
 - o 7A, 30VDC or 7A 120VAC max, 100mA 5VDC | min, no power supplied, simply a contact closure
 - o Trigger relay at specified speed with configurable duration from 1 to 10 seconds per radar event
- **Tamper Alarm:** ATS 5 or ATS 3 Trailer

Compatible with these ATS Products

Engineered and manufactured in the United States of America

- 1 & 2. SpeedAlert 18 Pole Mount
3. SpeedAlert 18 on ATS 5 Trailer
4. SpeedAlert 18 with Full Wrap YOUR SPEED Sign (White or Red)



SpeedAlert Mounting Options

- Pole mount standard with included bracket, hardware
- NCHRP 350 approved on 4" pole (Letter SS-135)
- ATS 5 Trailer (refer to ATS 5 specifications for more information)
- ATS 3 Trailer (refer to ATS 3 specifications for more info)
- **Vehicle Hitch Mount**
 - o Mounts sign 30" to bottom of sign from receiver tube (final height dependent on receiver height)
 - o Fits 1 ¼" or 2" receiver, adapter included, ½" hitch pin
 - o Locking rotation adjustment on 15 degree increments over 180 degrees, +/- 5 degrees tilt
 - o White powder coat finish with rear reflector
- **Standard Folding Portable Post**
 - o Folds for easy storage and portability
 - o **IA18:** 60" to 73" to bottom, 80" to 93" to top of sign depending on leg positions
- Mounting provisions for permanent applications with ¼"-20 threaded holes

Warranty

- 1-year warranty (three months on Li-Ion batteries)
 - o Product software upgrades free

SpeedAlert 18 Mounting Bracket and Mounting Holes

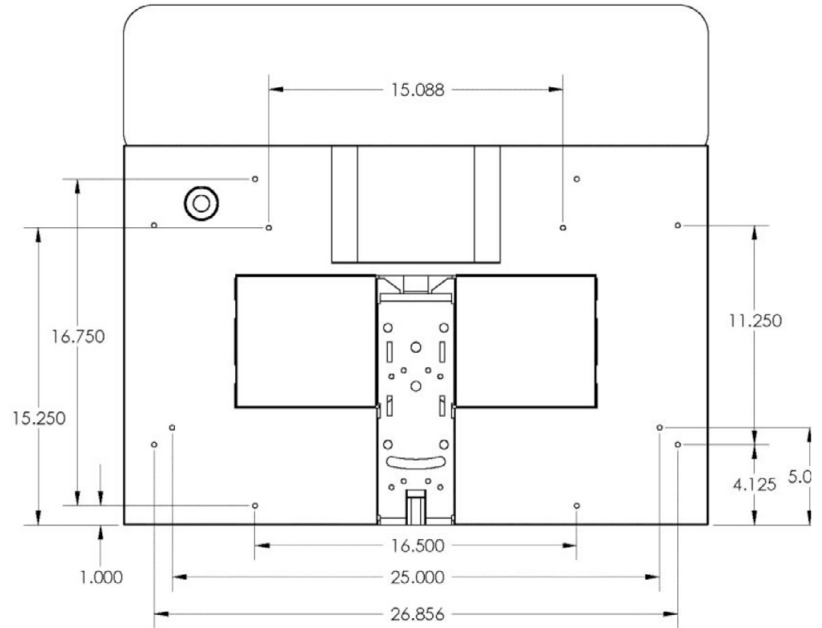
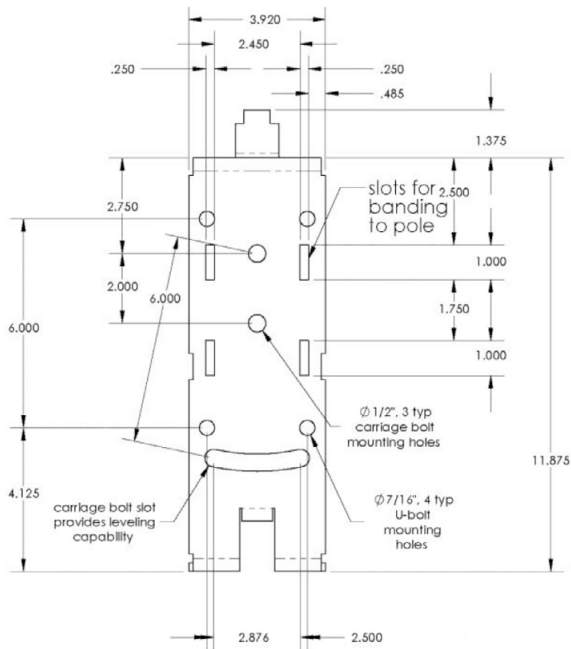

Additional Mounting Provisions:
1/4-20 thread, captive nuts

SpeedAlert 18 Dimensions

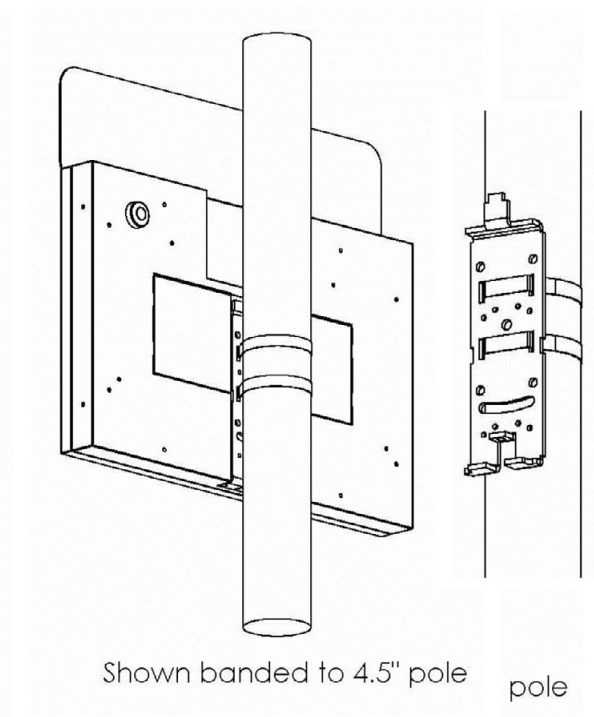
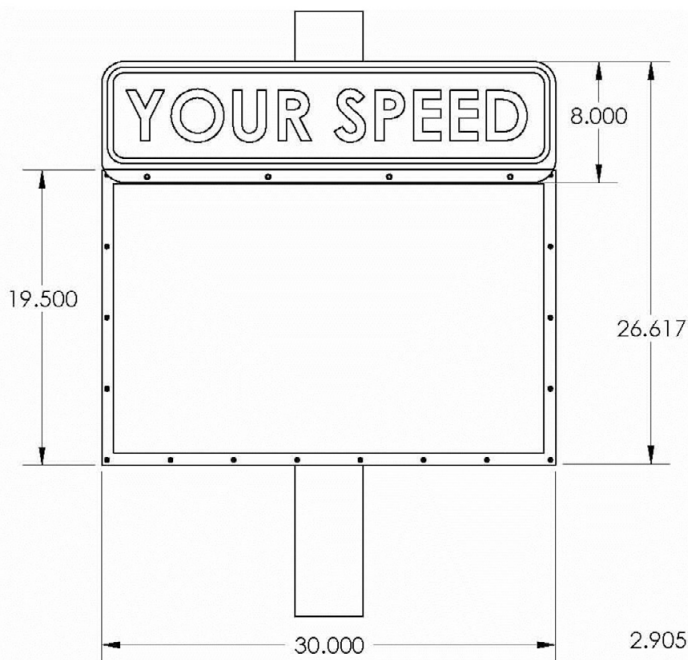

SpeedAlert 18 with Trailer Mounting Brackets Installed – for Installation on Existing Trailers for Trade In

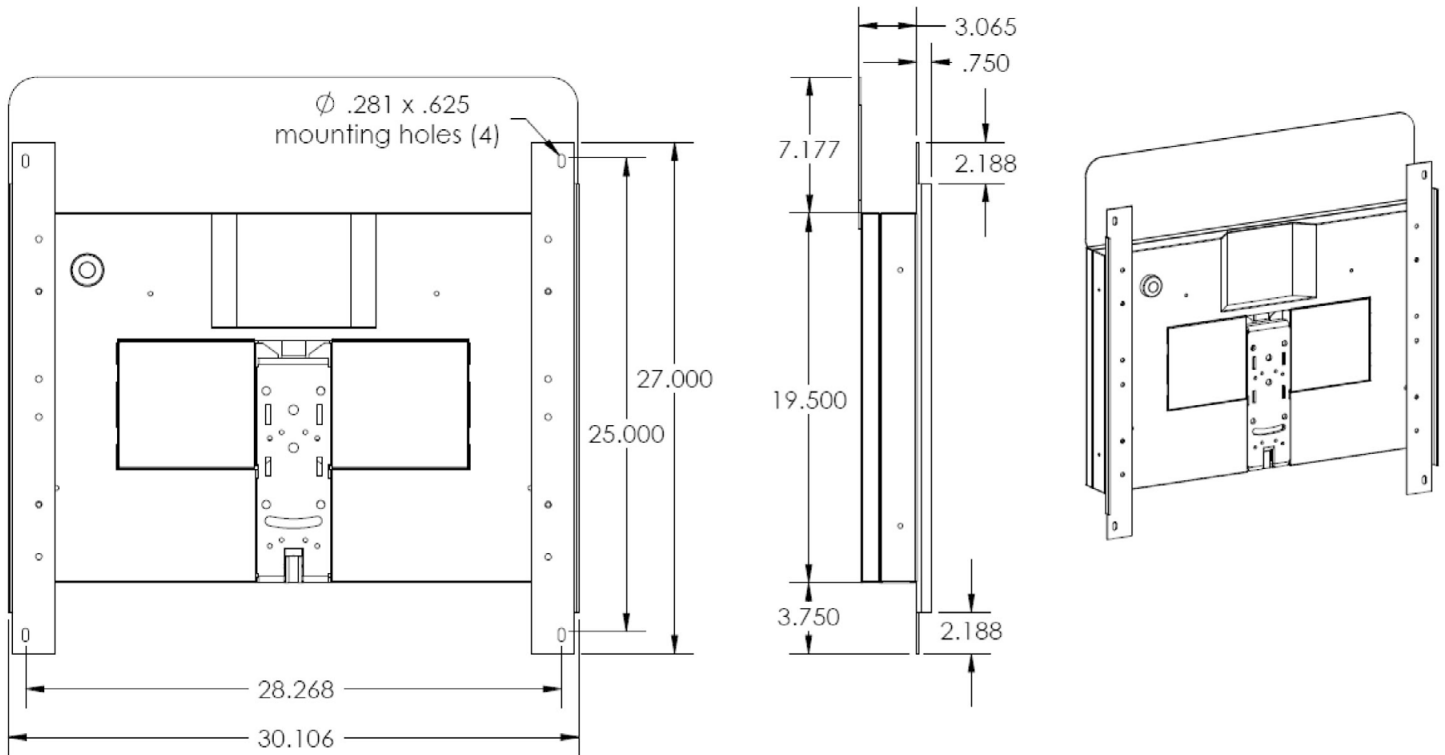

All Traffic Solutions 12950 Worldgate Drive, Suite 310, Herndon, VA 20170

Phone 866.366.6602 | sales@alltrafficsolutions.com | AllTrafficSolutions.com

©All Traffic Solutions

TraffiCloud leverages our patented technology (US Patents 8,417,442; 8,755,990; 9,070,287; 9,411,893) to deliver unique cloud-based management, features and functionality.



Clifton Clerk <clerk@cliftonva.gov>

traffic speed control

1 message

themichellestein@gmail.com <themichellestein@gmail.com>

Tue, Sep 6, 2022 at 11:41 AM

To: Darrell Poe <dpoe@cliftonva.gov>, Lynn Screen <lscreen@cliftonva.gov>, ppline@cliftonva.gov, Regan McDonald <rmcdonald@cliftonva.gov>, seffros@cliftonva.gov, William Hollaway <whollaway@cliftonva.gov>

Cc: Clifton Clerk <clerk@cliftonva.gov>

I am in favor of speed control devices.

I am concerned about the number of signs.

I do not think there should be one going uphill towards Clifton Heights. Speeding uphill above 25 is rare.

I suggest putting the ruble strips back in when entering town from both ends of Clifton Rd. The ones by Clifton Elem would certainly slow traffic. I have heard that there is a concern about noise from the ones behind Pline and Chesley but asking Pat and Jim would address that. There were probably much fewer accidents when the strips were in place.

Michelle Stein

themichellestein@gmail.com (new email as of Dec 2021)

703-539-8000 office

703-989-4376 cell



Clifton Clerk <clerk@cliftonva.gov>

Traffic calming measures

1 message

Matt & Susan Wright <mandswright3370@gmail.com>

Mon, Sep 5, 2022 at 5:56 PM

To: whollaway@cliftonva.gov, rmcdonald@cliftonva.gov, seffros@cliftonva.gov, cppline@cliftonva.gov, dpoe@cliftonva.gov, lscreen@cliftonva.gov, Clifton Clerk <clerk@cliftonva.gov>

Dear Clifton Town Council Members,

We live on Clifton Road (Route 645) heading out of town toward Route 123 (just behind Vice Mayor Regan McDonald). In the past five years we have had no fewer than 4 accidents in front of our drive way and on to our property. Drivers have been leaving town and accelerating out of the curves and losing control in one case rolling their vehicle. Or exceeding the 25mph speed limit headed into town and losing control. This issue has been a topic of conversation and concern of the entire town and with you all on the Town Council. I would like to recommend any measures that may be implemented on this end of town be placed between the Town limit sign and the 25mph sign on Clifton Rd. Personally I would like to see a speed hump similar to what we have in other parts of town in addition to the radar messaging sign that has been discussed. In this location the light from the radar message sign would not be an irritant to residents along the road as the houses are elevated from the road. To place any measure closer to down town will not give drivers time to adjust their speed either before the curves into town or impact their behavior as they come around the curves heading out of town. Thank for taking our recommendation into consideration when making a final decision around this issue.

Sincerely,
Matt & Susan Wright
7179 Clifton Road

Sent from my iPad

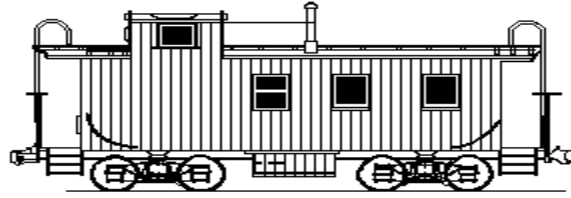

**CLIFTON TOWN COUNCIL MEETING
TUESDAY, SEPTEMBER 6, 2022, 7:30 PM
ELECTRONIC MEETING VIA ZOOM
12641 CHAPEL ROAD
CLIFTON, VA 20124**

In accordance with the Town of Clifton's Declaration of a Local Emergency due to the COVID-19 pandemic under Virginia Code § 44-146.21 which enables the Town of Clifton Government bodies to conduct Town business through electronic public meetings under Virginia Code § 2.2-3708.2, the Town of Clifton Town Council is holding the Meeting noticed herein electronically for the purpose of continuity of government of the Town of Clifton.

The meeting will be conducted using Zoom teleconferencing audio and video service, and connection information will be provided to members of the public to afford the opportunity to citizens to witness the operation of the Town of Clifton government. Connection information is available from, and will be provided by, the Town Clerk.

Order of Business

1. Report of the Town Clerk:
 - a. Approval of the Minutes (previous meetings, special meetings, and work sessions).
2. Report of the Treasurer.
 - a. Approval of Treasurer's Report.
3. Citizen's Remarks - Suggestions or complaints of citizens and taxpayers, and other persons authorized by the Mayor to address the Council.

Each person wishing to address the Council shall, when recognized by the Mayor:

 - (i) Give their name and address;
 - (ii) Direct their remarks to the Council and not to other citizens present;
 - (iii) Be limited to one period of not over three (3) minutes, unless granted additional time by unanimous consent of the Council.

Persons requesting to speak must have registered with the Town Clerk by no later than Noon of the day of the meeting. Priority to speak shall be given to persons in order registered with the Town Clerk.
4. Reports of Committees:
 - a. Planning Commission.
 - b. Report of the Zoning Administrator:
 - c. Architectural Review Board.
 - d. Streetscape Committee.
5. Unfinished Business:
 - a. Addition of ADA Accessible Parking Spaces in Town Parking Lot - Report.
 - b. Acquisition of Speed Alert Signs for Town of Clifton – Review and Approve Proposal.
 - c. Holiday Lighting for Town of Clifton - Update.
6. New Business:
 - a. Fairfax County Police Department – Sully Commander Community Meeting – Planning for November 17.

- b. Clifton Day – October 9:
 - i. Request to Use Town Properties;
 - ii. Banner Request – Banner Up September 24, Down One Week After Event.
 - c. Clifton Haunted Trail – October 29:
 - i. Presentation;
 - ii. Party/Planning Event – September 8;
 - iii. Request for Advance Funding;
 - iv. Banner Request – Banner Up Following Clifton Day, Down One Week After Event.
 - d. Banner Request for Clifton Lions Club/DEA Drug Take Back Day – October 29 – Banner Up October 15, Down One Week After Event.
 - e. Holiday Arts & Crafts Festival – Town of Clifton and Art Guild – December 3.
 - f. Holiday Tree Lighting Event – December 3.
 - g. Second Baptist Church Update – New Pastor – Rev. Dr. Jerome Allen Bell.
 - h. Project Commitment Tracking Process.
7. Adjournment.